

- 1 COCKPIT SHOWER
- 2 HEAD SHOWER
- 3 SALT WATER PUMP
- 4 FRESH WATER PUMP
- 5 ACCUMULATOR TANK
- 6 WATER FILTER
- 7 SALT WATER INTAKE
- 8 SALT PUMP
- 9 Y VALVE

- FRESH WATER COLD
- - - FRESH WATER HOT
- SALT WATER
- ⊥ OR — SEACOCK OUT

NOTE THIS DRAWING IS A SCHEMATIC LOCATIONS OF HOSES AND FITTINGS ARE NOT EXACT, BUT ARE LAYED OUT TO SHOW FLOW OF WATER ONLY.

F-32

REV	DESCRIPTION	DATE	BY	CHKD
P-32 PLUMBING DIAGRAM				
DWG. NO. F-32-20450				
TE. PL. PART NO.	DATE	BY	CHKD	DATE
SCALE: 1/2" = 1'-0"	12-28-50	W. J. H.	W. J. H.	12-28-50
DRWN BY: W. J. H.	CHKD BY: W. J. H.	DATE: 12-28-50	SHEET 1 OF 1	
TILLOTSON-PEARSON, INC.				
171 12th MARKET ST.		BIRD BEAT BARR		
BARRING, N.J. 08004		SEAFIELD-ROBERTS BLDG		
TEL. 609 884-2200		TEL. 609 882-2800		

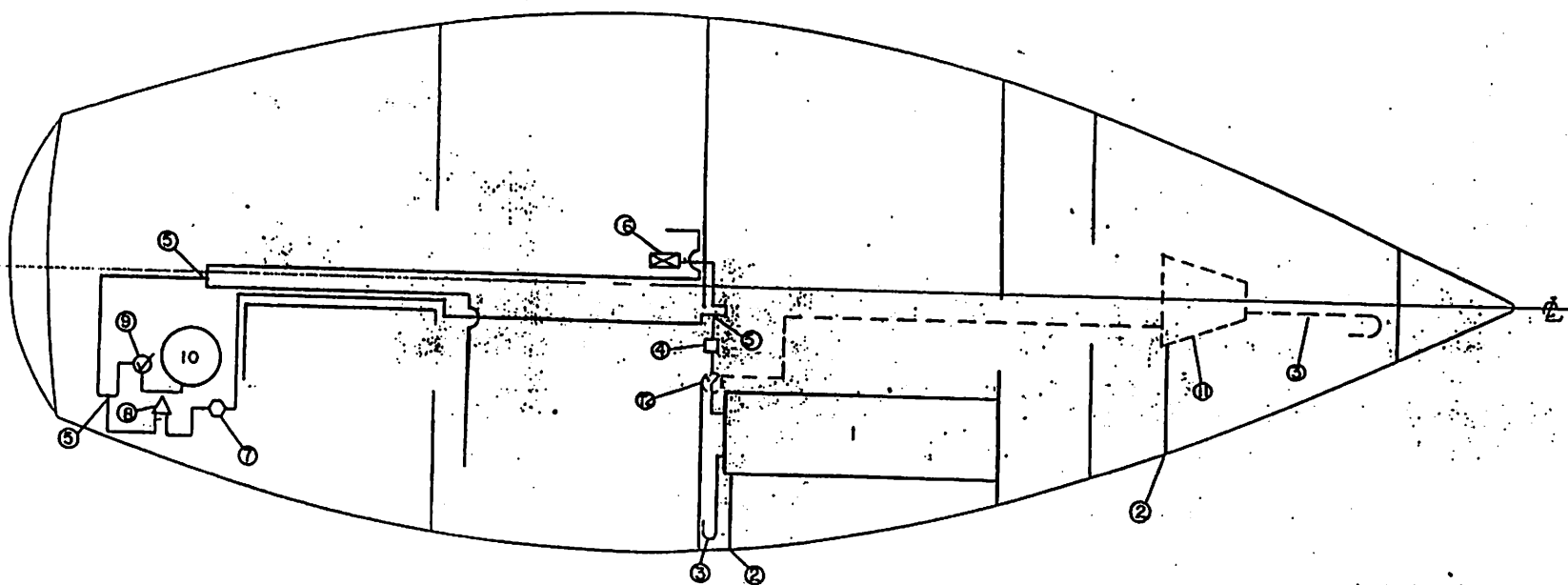

COLD WATER SYSTEM

I.P.I. PART NO.

F-32

- |                                 |       |
|---------------------------------|-------|
| 1. 55 GAL. FRESH WATER          | 23157 |
| 2. WATER FILL / DECK FITTING    | 10143 |
| 3. VENTED LOOP                  | 23162 |
| 4. STRAINER                     | 23148 |
| 5. "T" FITTING                  | 23018 |
| 6. HAND PUMP                    | 23006 |
| 7. PRESSURE PUMP                | 23166 |
| 8. ACCUMULATOR                  | 23016 |
| 9. CHECK VALVE                  | 23026 |
| 10. 6 GAL. WATER HEATER         | 23025 |
| 11. 60 GAL. V-BERTH TANK (OPT.) | 23216 |
| 12. "Y" VALVE (OPT.)            |       |

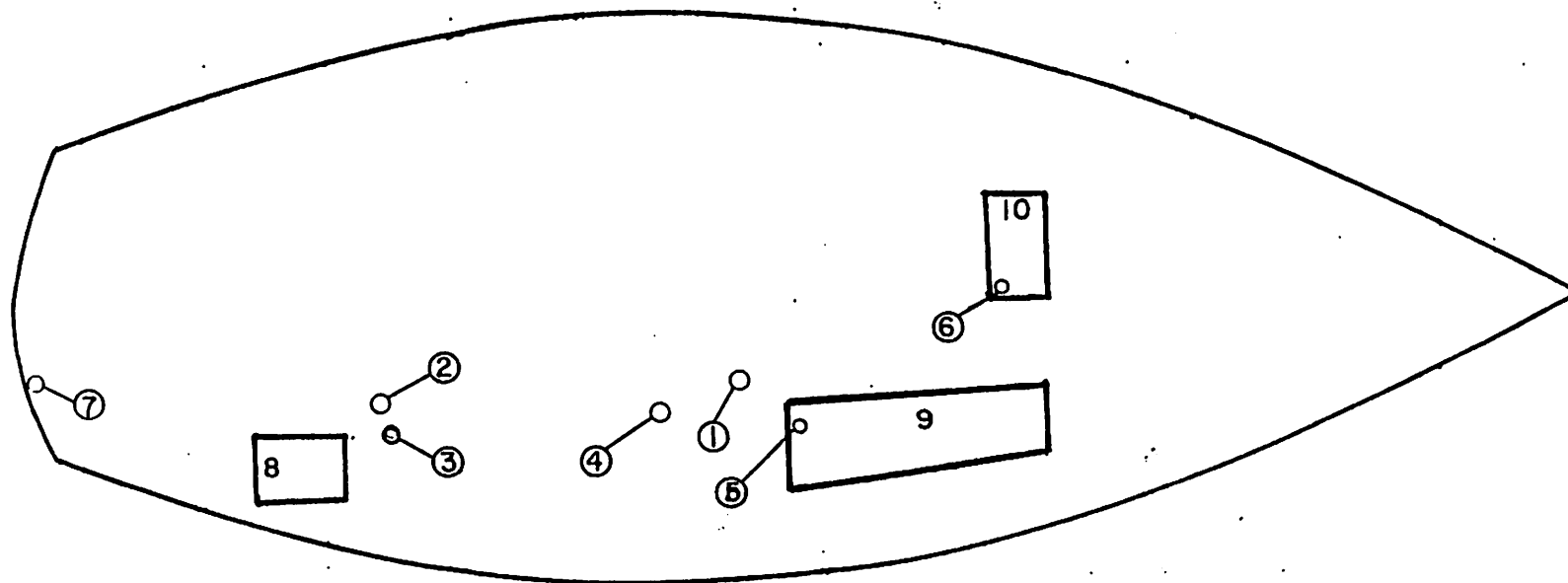

FREEDOM 32  
TANK AND VALVE LOCATIONS

- |                        |        |
|------------------------|--------|
| 1. ENGINE INTAKE       | 3/4"   |
| 2. HEAD DISCHARE       | 1 1/2" |
| 3. HEAD INTAKE         | 3/4"   |
| 4. SINK DISCHARGE      | 1 1/2" |
| 5. WATER SHUT OFF      |        |
| 6. FUEL SHUT OFF       |        |
| 7. BILGE PUMP OUTLET   |        |
| 8. WASTE TANK, 12 GAL. |        |
| 9. WATER TANK, 50 GAL. |        |
| 10. FUEL TANK, 28 GAL. |        |

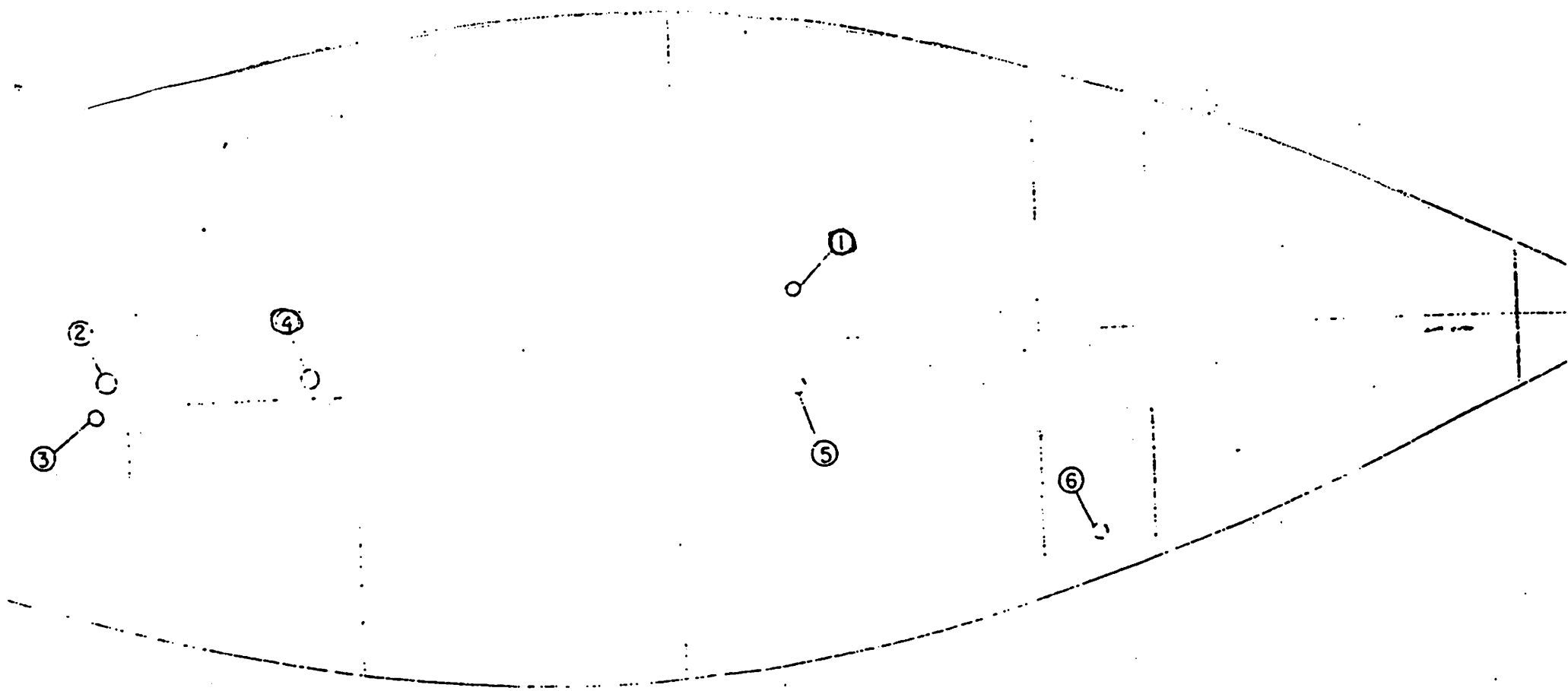

THRU HULL LOCATIONS

I. P. I. PART NO.

1.	3/4" ENGINE INTAKE	19008 W/23043
2.	1 1/2" HEAD DISCHARGE	23048 W/23041
3.	3/4" HEAD INTAKE	23049 W/23043
4.	1 1/2" DISCHARGE FOR SINKS	23048 W/23194 & 23206
5.	3/4" INTAKE GALLEY PUMP (OPTION)	23049 W/23043
6.	3/4" SINK DISCHARGE (OPTION)	23062 W/23043